

Clutch

Table of Contents

Exploded View	6-2
Specifications	6-3
Clutch Lever and Cable	6-4
Lever Free Play Inspection	6-4
Lever Free Play Adjustment.....	6-4
Cable Removal	6-4
Cable Installation	6-4
Cable Lubrication	6-4
Clutch Lever Installation.....	6-4
Clutch Cover.....	6-5
Clutch Cover Removal	6-5
Clutch Cover Installation	6-5
Release Shaft Removal	6-6
Release Shaft Installation	6-6
Clutch Cover Disassembly.....	6-6
Clutch Cover Assembly.....	6-7
Clutch	6-8
Clutch Removal.....	6-8
Clutch Installation.....	6-9
Clutch Plate Assembly Inspection.....	6-11
Clutch Plate Assembly Adjustment	6-11
Clutch Plate, Wear, Damage Inspection	6-12
Clutch Plate Warp Inspection.....	6-12
Clutch Spring Free Length Measurement.....	6-12

6-2 CLUTCH

Exploded View

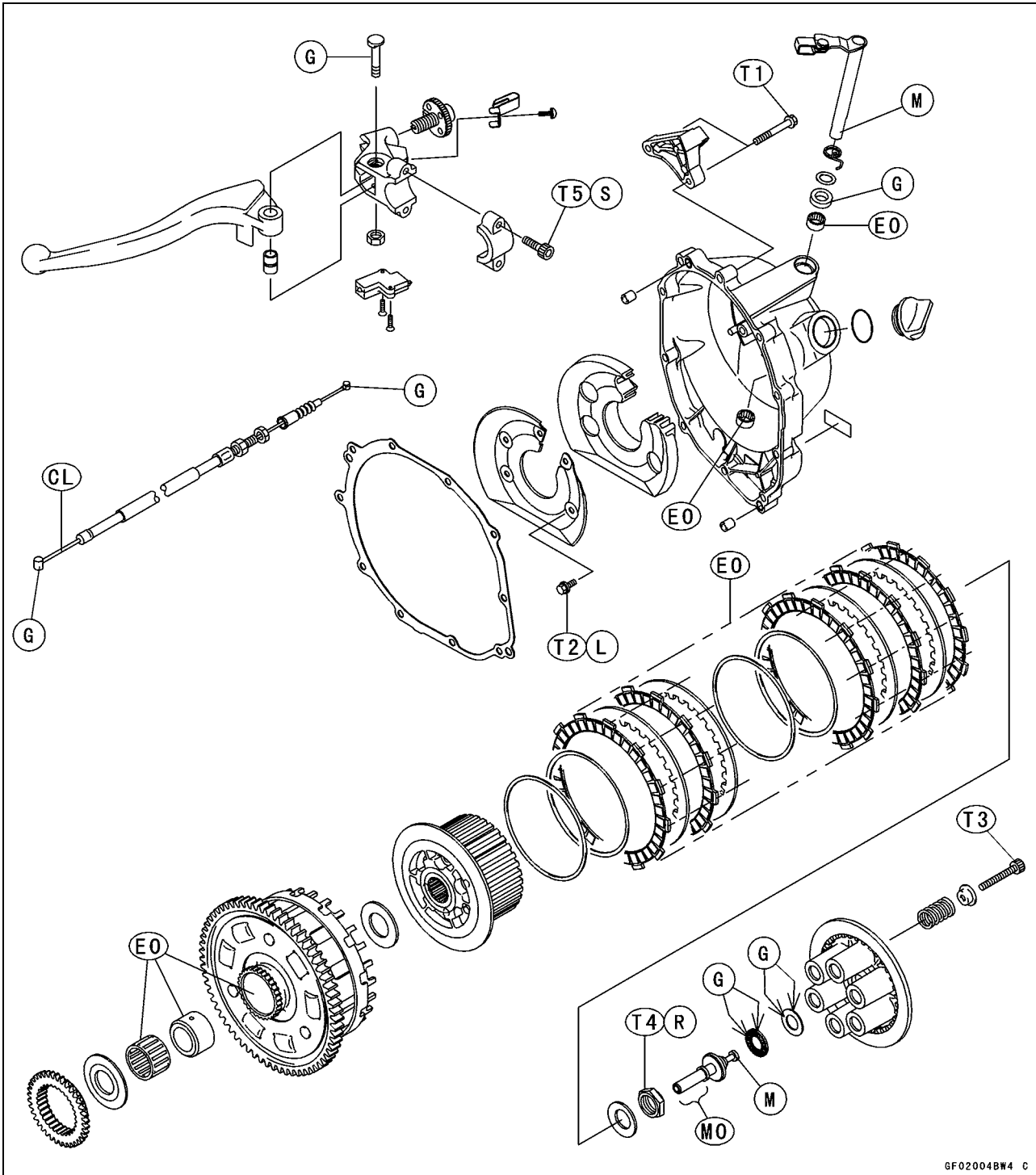

GF02004BW4 C

T1: 15 N·m (1.5 kgf·m, 11 ft·lb)

T2: 7.0 N·m (0.70 kgf·m, 62 in·lb)

T3: 8.8 N·m (0.90 kgf·m, 78 in·lb)

T4: 135 N·m (14 kgf·m, 100 ft·lb)

T5: 7.8 N·m (0.80 kgf·m, 69 in·lb)

CL: Apply cable lubricant.

EO: Apply engine oil.

G: Apply grease.

L: Apply a non-permanent locking agent.

M: Apply molybdenum disulfide grease.

MO: Apply molybdenum disulfide oil solution.

R: Replacement Parts

S: Follow the specific tightening sequence.

Specifications

Item	Standard	Service Limit
Clutch Lever Free Play	2 ~ 3 mm (0.08 ~ 0.12 in.)	- - -
Clutch		
Friction Plate Thickness	3.22 ~ 3.38 mm (0.127 ~ 0.133 in.)	3.0 mm (0.12 in.)
Friction and Steel Plate Warp	0.15 mm (0.0059 in.) or less	0.3 mm (0.01 in.)
Clutch Plate Assembly Length	56.8 ~ 57.6 mm (2.24 ~ 2.27 in.)	- - -
Clutch Spring Free Length	73.49 mm (2.893 in.)	68.5 mm (2.70 in.)

Special Tools - Clutch Holder: 57001-1243

Clutch Gear Setting: 57001-1455

Sealant - Kawasaki Bond (Silicone Sealant): 56019-120

6-4 CLUTCH

Clutch Lever and Cable

Lever Free Play Inspection

- Refer to the Clutch Adjust Inspection in the Periodic Maintenance chapter.

Lever Free Play Adjustment

- Refer to the Clutch Adjust Inspection in the Periodic Maintenance chapter.

Cable Removal

- Remove the right lower inner cover (see Frame chapter).
- Slide the dust cover [A] at the clutch cable lower end out of place.
- Loosen the nuts [B], and slide the outer of the clutch cable to the lower side.

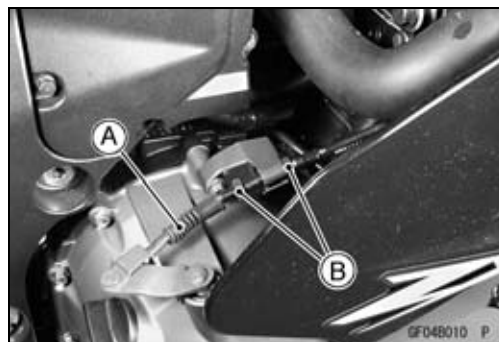

- Screw in the adjuster.
- Line up the slots [A] in the clutch lever [B] and adjuster [C], and then free the cable from the lever.
- While pushing the stopper [E], turn the adjuster.
- Free the clutch inner cable tip from the clutch release lever.
- Push the release lever toward the front of the motorcycle and tape the release lever to the clutch cover to prevent the release shaft from falling out.
- Pull the clutch cable out of the frame.

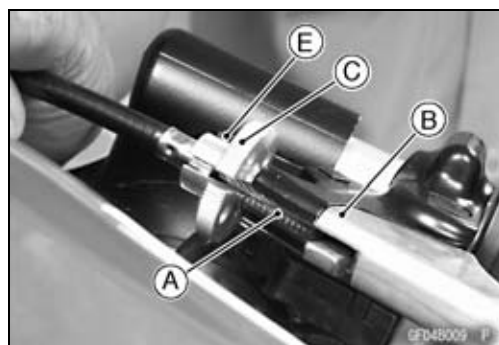

Cable Installation

- Run the clutch cable correctly (see General Information chapter).
- Adjust the clutch cable (see Clutch Adjust Inspection in the Periodic Maintenance chapter).

Cable Lubrication

- Refer to the General Lubrication in the Periodic Maintenance chapter.

Clutch Lever Installation

- Install the clutch lever [A] so that the mating surface [B] of the switch housing is aligned with the mating surface [C] of the clutch lever clamp.
- Tighten the upper clamp bolt first, and then the lower clamp bolt. There will be a gap at the lower part of the clamp after tightening.

Torque - Clutch Lever Clamp Bolts: 7.8 N·m (0.80 kgf·m, 69 in·lb)

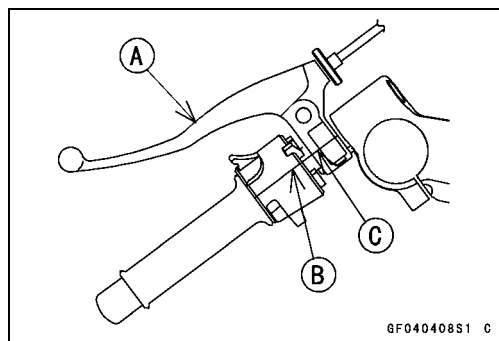

Clutch Cover

Clutch Cover Removal

- Set the motorcycle on its side stand, squeeze the front brake lever, and hold it with a band [A] to prevent the motorcycle from running forward.

⚠ WARNING

Be sure to hold the front brake when removing the clutch, or the motorcycle may fall over. It could cause an accident and injury.

CAUTION

Be sure to hold the front brake when removing the clutch, or the motorcycle may fall over. The motorcycle could be damaged.

- Remove:
 - Right Lower Fairing (see Frame chapter)
 - Clutch Cover Mounting Bolts [B]
 - Clutch Cable Bracket [C]
 - Clutch Cable Lower End [A]

- Turn the release lever [B] toward the rear [C] as shown, and remove the clutch cover [A].

CAUTION

Do not remove the clutch release lever and shaft assembly unless it is absolutely necessary. If removed, the oil seal replacement may be required.

Clutch Cover Installation

- Apply silicone sealant to the area [A] where the mating surface of the crankcase touches the clutch cover gasket.
- Be sure to install the pins [B].

Sealant - Kawasaki Bond (Silicone Sealant): 56019-120

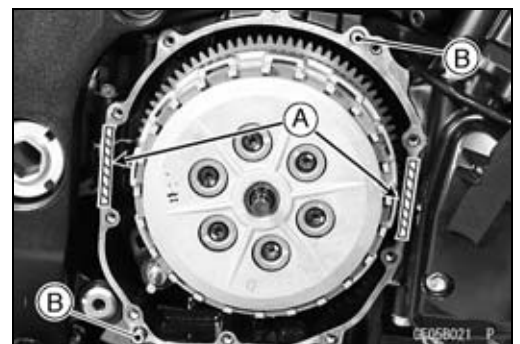
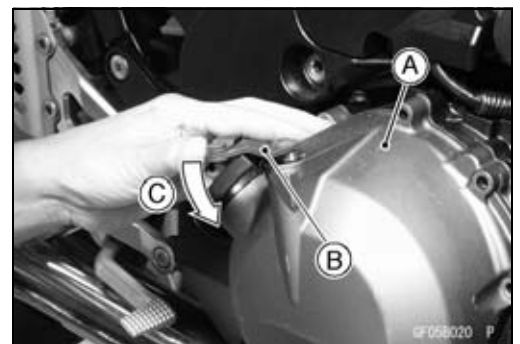
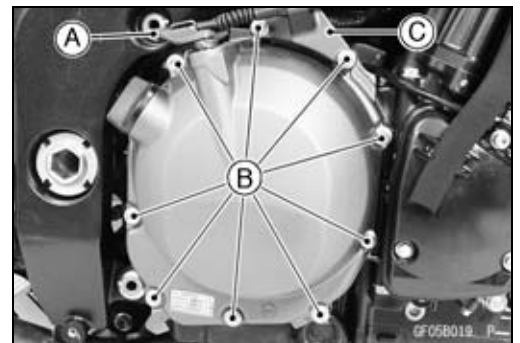

6-6 CLUTCH

Clutch Cover

- Replace the cover gasket with a new one.
- Apply a non-permanent locking agent to the two cover bolts [A] only.
- Tighten the cover bolts.

Torque - Clutch Cover Bolts: 15 N·m (1.5 kgf·m, 11 ft·lb)



Release Shaft Removal

- Remove the clutch cable lower end (see Clutch Cable Removal).
- Turn the release lever [A] toward the right about 45° [B] and pull the lever and shaft assembly straight out of the clutch cover.

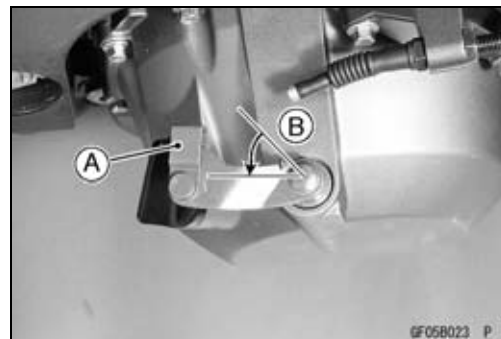

Release Shaft Installation

- Apply oil to the needle bearings in the hole of the clutch cover.
- Apply high-temperature grease to the oil seal lips of the clutch cover.
- Apply molybdenum disulfide grease to the pusher-holding portion on the release shaft.
- Insert the release shaft [A] straight into the upper hole of the clutch cover.
 - Spring [B]
 - Washer [C]

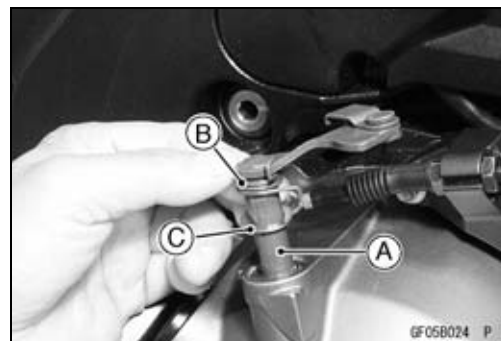

CAUTION

When inserting the release shaft, be careful not to remove the spring of the oil seal.

Clutch Cover Disassembly

- Remove the clutch cover (see Clutch Cover Removal).
- Pull out the release shaft (see Release Shaft Removal).
- Remove:
 - Damper Plate Bolts [A]
 - Damper Plate [B]
 - Damper

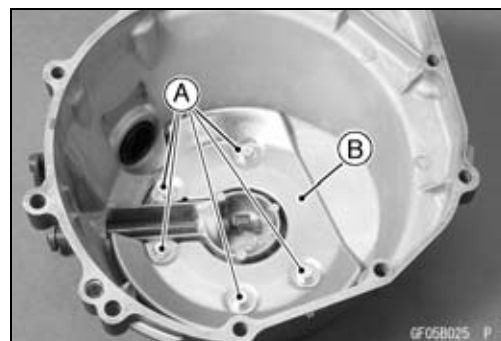

Clutch Cover

- Remove:
 - Oil Seal [A]
 - Needle Bearings [B]

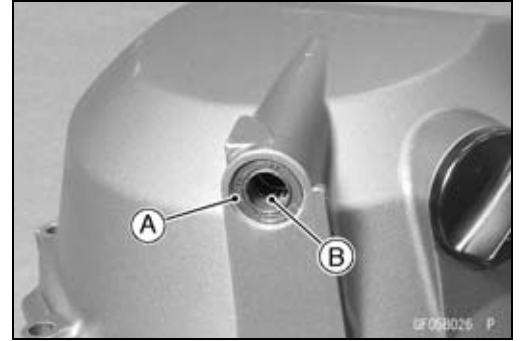

Clutch Cover Assembly

- Replace the needle bearings and oil seal with new one.

NOTE

- Install the needle bearings so that the manufacturer's mark face out.
- Install the needle bearings [A] and oil seal [B] position as shown.

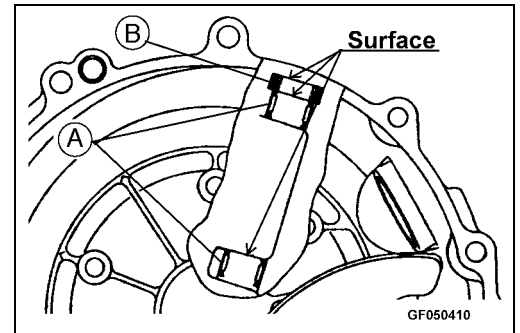

- Apply a non-permanent locking agent to the damper plate bolts and tighten them.
- Confirm that the torque to fast tightened bolt.

Torque - Clutch Cover Damper Plate Bolts: 7.0 N·m (0.70 kgf·m, 62 in·lb)

6-8 CLUTCH

Clutch

Clutch Removal

- Remove:
 - Right Lower Fairing (see Frame chapter)
 - Clutch Cover (see Clutch Cover Removal)
 - Clutch Spring Bolts [A]
 - Clutch Springs
 - Clutch Spring Plate [B] (with thrust bearing, pusher [C] and washer)

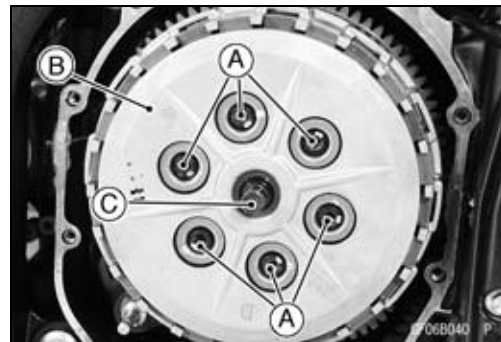

- Remove:
 - Friction Plates [A]
 - Steel Plates
 - Springs
 - Spring Seats



- Holding the clutch hub [A], remove the nut [B] and washer [C]

Special Tool - Clutch Holder: 57001-1243 [D]

- Remove:
 - Clutch Hub

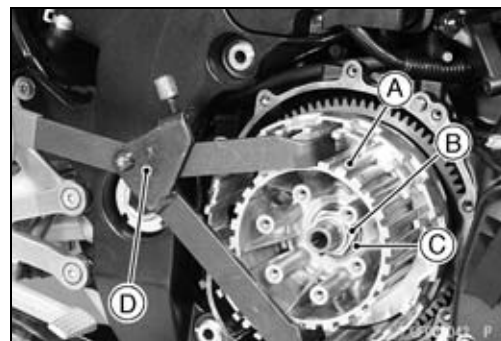

- Insert the clutch gear setting [A] to the hole of the clutch housing.
- Position the hole [B] of the clutch housing at the front side of the engine so that the tip of the gear setting does not hit the crankcase wall.
- Align the teeth of the clutch housing gears by the gear setting.

Special Tool - Clutch Gear Setting: 57001-1455

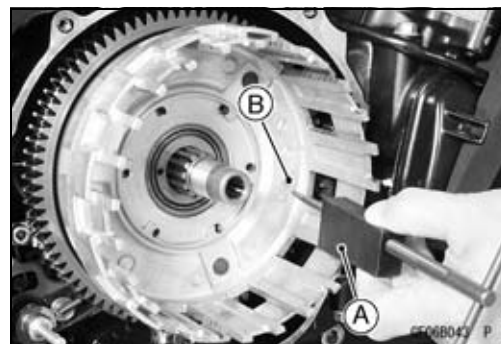

- Pull out the sleeve [A] from the clutch housing [B], and remove the housing.
- If the sleeve does not pull out easily, insert M4 bolts [C] into the threaded hole of the sleeve, and pull out the sleeve.
- Remove the thrust washer.



Clutch

Clutch Installation

- Install the thrust washer [A] by facing its chamfered side [B] towards the crankcase.

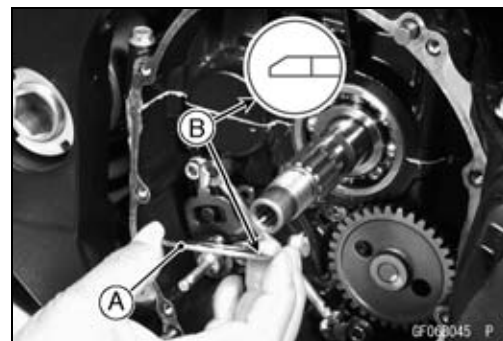

- Install the oil pump drive gear [A] on the clutch housing.



- Align the teeth of the clutch housing gears by the gear setting [A].
- Install the clutch housing so that the hole position forward of the engine.

Special Tool - Clutch Gear Setting: 57001-1455

- Install:
 - Clutch Housing
 - Needle Bearing
 - Sleeve

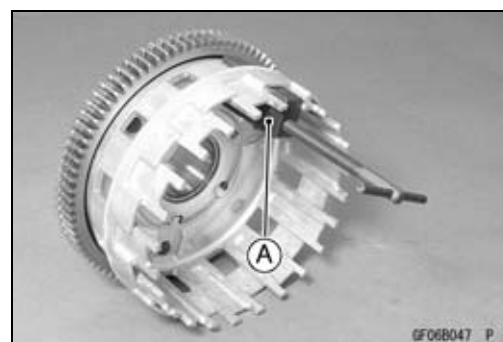

- Apply engine oil to the needle bearing and the sleeve before installation.

- Install the washer [A] so that the OUT SIDE mark [B] faces outward.

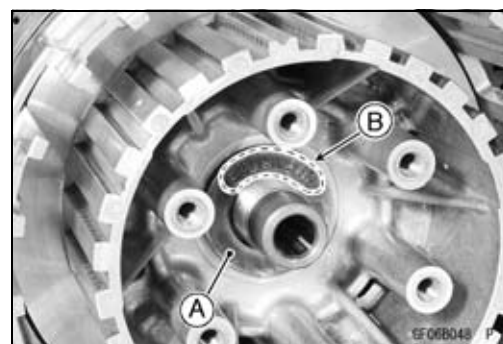

- Replace the clutch hub nut with a new one.
- Holding the clutch hub, tighten the clutch hub nut with the torque wrench [B].

Special Tool - Clutch Holder [A]: 57001-1243

Torque - Clutch Hub Nut: 135 N·m (14 kgf·m, 100 ft·lb)

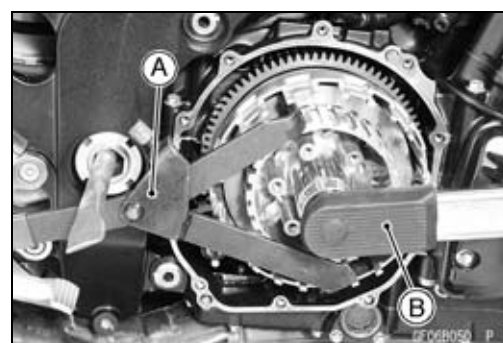

6-10 CLUTCH

Clutch

- Install the spring seats [D] [F], springs [E], friction plates [A] [C] [H] and steel plates [B] as shown.

NOTE

- The inside diameter of first and seventh friction plates are larger than the others because the spring seats and springs are equipped to decrease the judder noise as shown.

Clutch Hub [G]

CAUTION

If new dry friction plates and steel plates are installed, apply engine oil to the surfaces of each plate to avoid clutch plate seizure.

- Install outer-end friction plate, that has the narrowest groove [A] among others.

- Install the last friction plate [A] fitting the tangs in the grooves in the housing as shown.

- Apply molybdenum disulfide oil solution [MO] to the outside surface of the pusher [A], then install the pusher into the drive shaft.
- Apply high-temperature grease [G] to both side of needle bearing [B] and washer [C], then install them onto the pusher.
- Apply molybdenum disulfide grease [M] to the mating surface of the pusher.

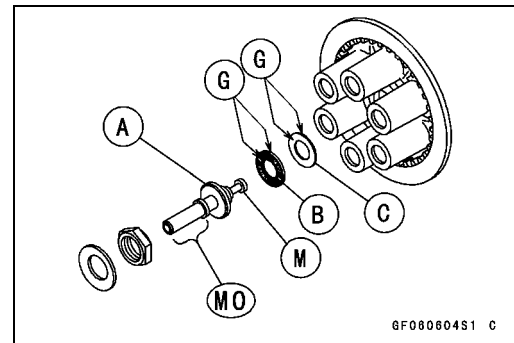
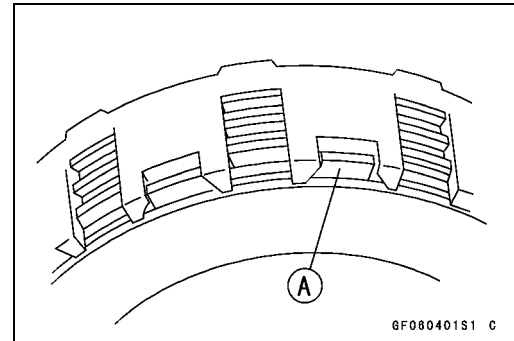
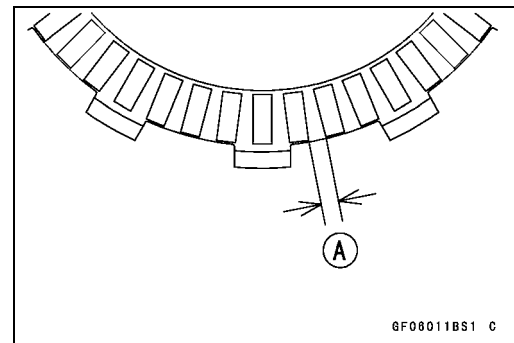
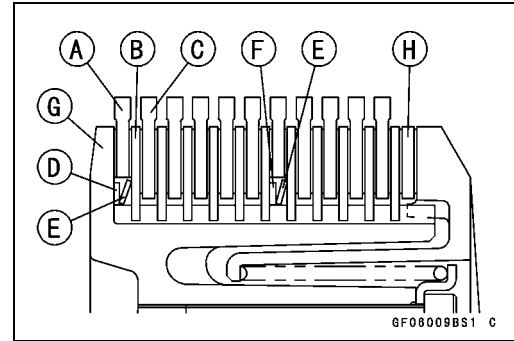

Clutch

- Align the mark [A] of the spring plate [B] to one of the grooves [C] of the clutch hub [D] to install the spring plate on the clutch hub.
- Install the spring, and tighten the clutch spring bolts evenly.

Torque - Clutch Spring Bolts: 8.8 N·m (0.90 kgf·m, 78 in·lb)

- Install the clutch cover (see Clutch Cover Installation).

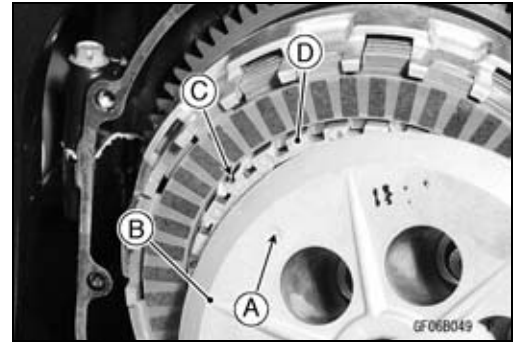

Clutch Plate Assembly Inspection

- Inspect the friction plate thickness (see Clutch Plate, Wear, Damage Inspection).
- Measure the length [A] of the clutch plate assembly as shown.

○Assemble:

- Clutch Hub [B]
- Spring Seats [C] [K]
- Springs [D]
- Friction Plates [E] [L] [M]
- Steel Plates [F]
- Spring Plate [G]
- Springs [H]
- Spring Seats [I]
- Spring Bolts [J]

Torque - Clutch Spring Bolts: 8.8 N·m (0.90 kgf·m, 78 in·lb)

Clutch Plate Assembly Length

Standard: 56.8 ~ 57.6 mm (2.24 ~ 2.27 in.)

- ★If the length is not within the specified range, adjust the length (see Clutch Plate Assembly Adjustment).

Clutch Plate Assembly Adjustment

- Inspect the clutch plate assembly length, and then replace the steel plate(s) which brings the length within the specified range.

○Remove:

- Spring Bolts
- Springs
- Spring Holders
- Spring Plate
- Clutch Plates

○Replace the following steel plate(s).

Part Number	Thickness
13089-1125	1.4 mm (0.055 in.)
13089-1123	1.6 mm (0.063 in.) (Standard)
13089-1124	2.0 mm (0.079 in.)

NOTE

○Do not use the steel plate of 2.0 mm (0.079 in.) and 1.4 mm (0.055 in.) thickness at the same time.

- Install the removed parts, and inspect the clutch plate assembly length.

Torque - Clutch Spring Bolts: 8.8 N·m (0.90 kgf·m, 78 in·lb)

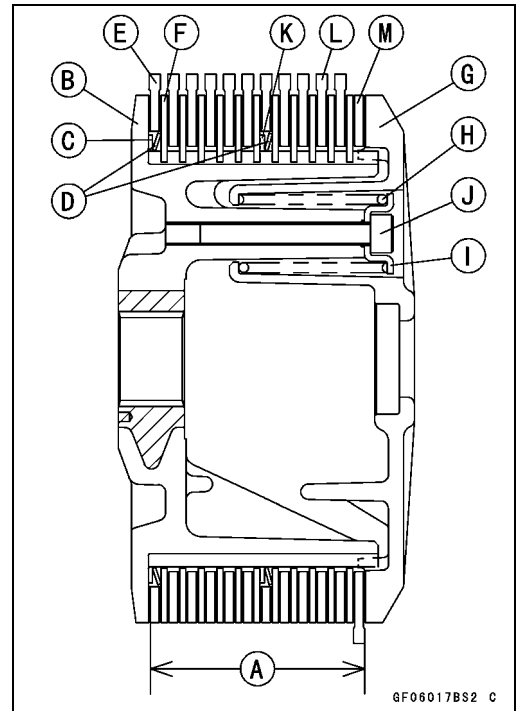

6-12 CLUTCH

Clutch

Clutch Plate, Wear, Damage Inspection

- Visually inspect the friction and steel plates for signs of seizure, overheating (discoloration), or uneven wear.
- Measure the thickness of the friction plate [A] at several points.
- ★ If any plates show signs of damage, or if they have worn past the service limit, replace them with new ones.

Friction Plate Thickness

Standard: 3.22 ~ 3.38 mm (0.127 ~ 0.133 in.)

Service Limit: 3.0 mm (0.12 in.)

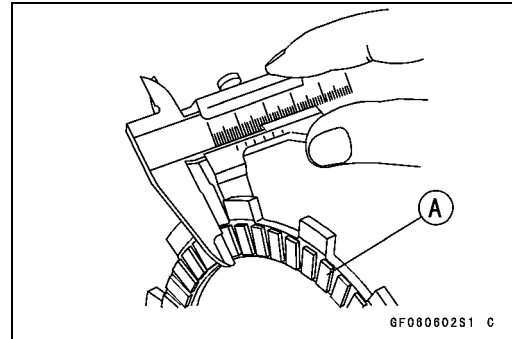

Clutch Plate Warp Inspection

- Place each friction plate or steel plate on a surface plate and measure the gap between the surface plate [A] and each friction plate or steel plate [B] with a thickness gauge [C]. The gap is the amount of friction or steel plate warp.
- ★ If any plate is warped over the service limit, replace it with a new one.

Friction and Steel Plate Warp

Standard: 0.15 mm (0.0059 in.) or less

Service Limit: 0.3 mm (0.01 in.)

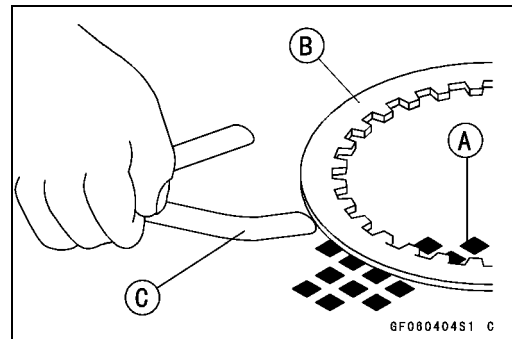

Clutch Spring Free Length Measurement

- Measure the free length [A] of the clutch springs.
- ★ If any spring is shorter than the service limit, it must be replaced.

Clutch Spring Free Length

Standard: 73.49 mm (2.893 in.)

Service Limit: 68.5 mm (2.70 in.)

